

July 12, 2002

Case Number: Y 2002 1314

Findings of the Group Reported to: Arthur T. Corey				<input type="checkbox"/>	<input type="checkbox"/>	<input type="checkbox"/>	Test: Y chromosome			
<b>Sample ID:</b>	<input type="checkbox"/>	<input type="checkbox"/>	<input type="checkbox"/>	<input type="checkbox"/>	<b>Participants:</b>	<input type="checkbox"/>	<input type="checkbox"/>	<b>Sample Type Submitted:</b>	<input type="checkbox"/>	<input type="checkbox"/>
1314A	<input type="checkbox"/>	<input type="checkbox"/>	<input type="checkbox"/>	<input type="checkbox"/>	Thomas Corey	<input type="checkbox"/>	<input type="checkbox"/>	Buccal Swab		
1314B	<input type="checkbox"/>	<input type="checkbox"/>	<input type="checkbox"/>	<input type="checkbox"/>	Earl Cory	<input type="checkbox"/>	<input type="checkbox"/>	Buccal Swab		
1314C	<input type="checkbox"/>	<input type="checkbox"/>	<input type="checkbox"/>	<input type="checkbox"/>	Arthur T. Corey	<input type="checkbox"/>	<input type="checkbox"/>	Buccal Swab		
1314D	<input type="checkbox"/>	<input type="checkbox"/>	<input type="checkbox"/>	<input type="checkbox"/>	Charles H. Cory	<input type="checkbox"/>	<input type="checkbox"/>	Buccal Swab		
1314E	<input type="checkbox"/>	<input type="checkbox"/>	<input type="checkbox"/>	<input type="checkbox"/>	John H. Corey	<input type="checkbox"/>	<input type="checkbox"/>	Buccal Swab		
1314F	<input type="checkbox"/>	<input type="checkbox"/>	<input type="checkbox"/>	<input type="checkbox"/>	Fred Corey	<input type="checkbox"/>	<input type="checkbox"/>	Buccal Swab		
1314G	<input type="checkbox"/>	<input type="checkbox"/>	<input type="checkbox"/>	<input type="checkbox"/>	Alan Corey	<input type="checkbox"/>	<input type="checkbox"/>	Buccal Swab		

---

---

### Summary of Findings:

**Y chromosomal analysis was conducted on seven Corey individuals and three main lineages were identified (Appendix A, Figure 2).**

---

---

### Objectives:

Genealogical records indicate that there were three Cory/Corey progenitors who arrived in America from Britain circa 1635-1640. They are designated as John of Long Island, NY; William of Portsmouth, RI; and Thomas of Chelmsford, MA. 90% of Americans bearing this surname think they can trace their ancestry back to one of these three progenitors. It is suspected that John of Long Island is the father of William of Portsmouth though the evidence is purely circumstantial. William came to America as a small child from Bristol, England, and his father's name was John, while John Cory arrived from England around the same time with his young son, William. John Corey was scheduled to appear in court in Rhode Island in 1642 but disappeared. In 1643 a John Corey arrived in Long Island. It is believed that this man was really John Corey of Portsmouth. The other theory is that John Corey descended from a titled family from Bramerton, England. Individuals 1314D and 1314G who descend from John of Long Island, and 1314A, 1314E, and 1314F who descend from William of Portsmouth, have submitted biological samples to test these hypotheses. In addition, 1314C believes that his great grandfather Joseph from Voluntown, CT is descended from the William line. More specifically, 1314C believes he and 1314E (who has documented genealogy to William) are fourth cousins through the Revolutionary War Veteran Sheffield Cory/Corey.

Thomas of Chelmsford, MA shows no genealogical relationship with John of Long Island or William of Portsmouth. 1314B is a direct paternal descendent of Thomas and has submitted a biological sample to elucidate Thomas's relationship to John and William. Figure 1 represents a pedigree compiled from information provided by the participants.



Figure 1: Condensed male-line pedigree indicating relevant male members of the Corey family based on genealogy provided by the participants.

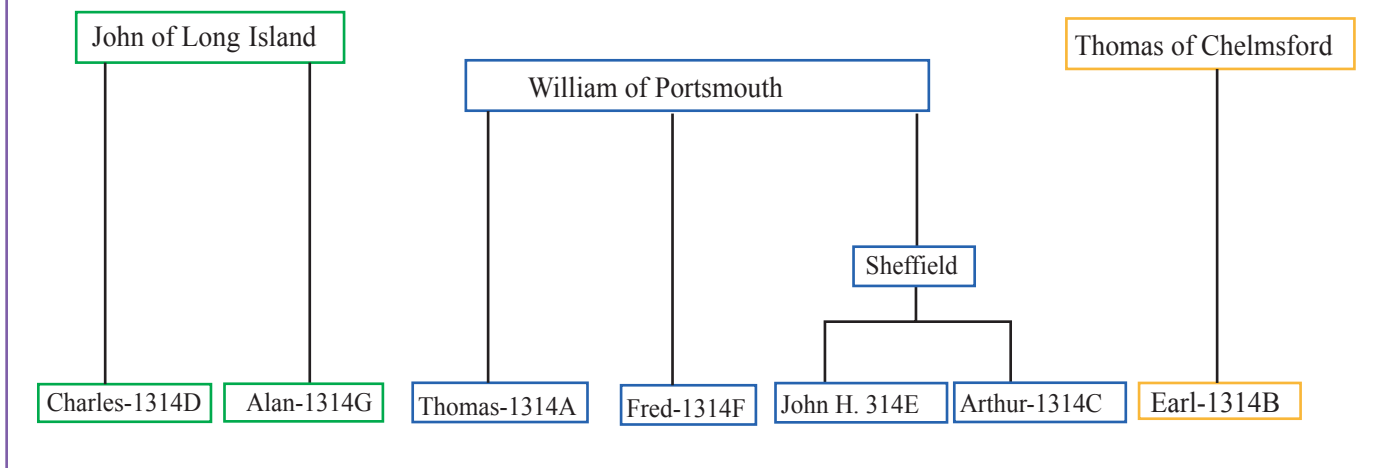

**Results:**

Y-chromosomal analysis of the seven participants identified three distinct Corey lineages (Appendix A and Figure 3). All individuals in the Corey lineages have different haplotypes. A comparison of all the haplotypes reveals that participants 1314D and 1314G share 22 of 23 alleles and form Corey Lineage 1. 1314A, 1314E and 1314F all share 21 of 23 alleles and form Corey Lineage 2. 1314B and 1314C share 22 of 23 alleles and from Corey Lineage 3. This information is also depicted in the Haplolocation diagram (Figure 2).

**Objective:** To determine if 1314C is a descendent of William of Portsmouth.

If Sheffield Cory/Corey is descended of William of Portsmouth, and E is a documented descendent of William and then Sheffield, it is very unlikely that C also shares that ancestry as C and E share only 8 of 23 alleles.

**Objective:** To determine if John of Long Island is the father of William of Portsmouth.

The ancestry of D and G was verified using genetic techniques as MRCA analysis places their common ancestor at 10 generations, or at about 1815 (Table 1). This means they may share a common ancestor before John of Long Island, but certainly they both descend from him. Likewise the three individuals who believed they descended from William of Portsmouth, A, E, and F, have verified their genealogy as the MRCA analysis shows they share a common ancestor at 20 generations, or at about 1690 (Table 1). The genetic evidence is also clear in showing that it is very unlikely that John of Long Island and William of Portsmouth are father and son because their verified descendents are not genetically similar. It is impossible to say if John of Long Island is instead a descendent of the Bramerton Coreys, however more genetic testing could be done to determine the true ancestry of both William and John.

	MRCA	95% Confidence Interval		Estimated year of birth for the common ancestor
		Lower Limit	Upper Limit	
D and G	10	1	28	1815
E, A, and F	20	4	46	1690
B with C	10	1	28	1815

**Table 1:** Estimation of intervening generations. Data is reported in number of generations. Please see the introduction for an explanation of how to count generations. The Year of Birth (YOB) estimation is based on 25 years per generation and an average participant birth year of 1940.

**Figure 2: Haplocation.** This diagram shows how subgroups in a family project are connected. To find out how genetically related two individuals are, count how many mutations, represented by boxes, separate the two individuals. The fewer boxes separating two individuals, the more closely they are related. As a general rule, individuals separated by more than three boxes are unlikely to be related in a genealogically reasonable number of generations.

Corey Lineage 1:

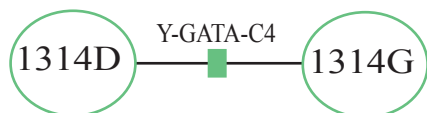

Each circle with a letter represents a participant.

Green denotes a single mutation, the site of the mutation is noted in black.

Corey Lineage 2:

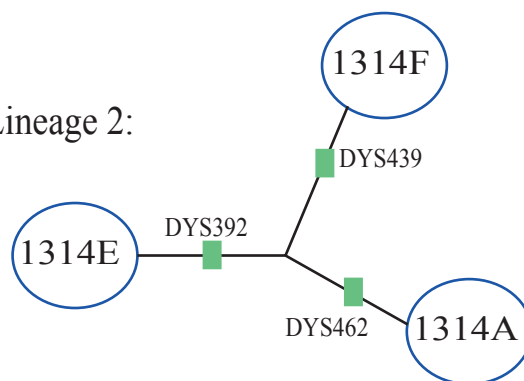

Corey Lineage 3:

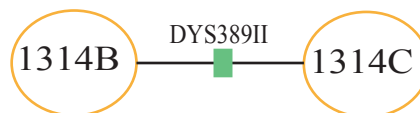

**Objective:** To determine the relationship, if any, between Thomas of Chelmsford, MA, John of Long Island, and William of Portsmouth.

The Y chromosome profile of 1314B, who represents the Thomas of Chelmsford line, did not match with any of the known descendants of William or John indicating there is no connection between the three lines. However, 1314C, a descendant of Joseph Corey of Voluntown, CT, shared 22 of 23 alleles with 1314B indicating that Joseph descended from Thomas of Chelmsford with an MRCA of 10 (Table 1).

**Figure 3: Genetic Pedigree-** Reconstruction of Corey family genealogies based on supplied genealogical information and genetic analysis.

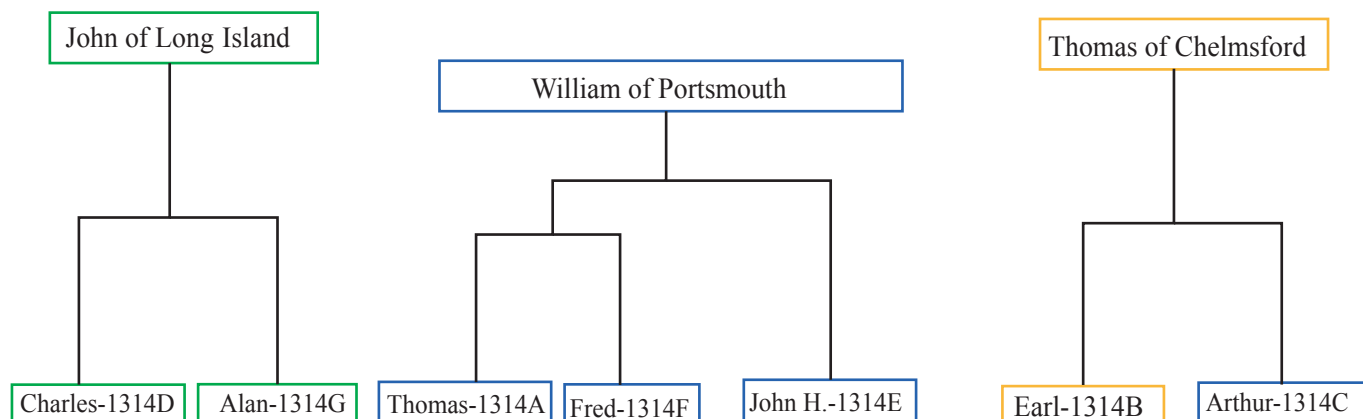

**Summary:**

The Corey Family Genetics Project was able to address all of the set objectives when DNA testing was used to verify and determine relationships using genetic techniques. If you have any questions regarding the information in this report, please contact Diahana Southard at (801) 461-9769, or at [diahana@relativegenetics.com](mailto:diahana@relativegenetics.com).

The undersigned have reviewed the above results and do hereby verify that they are accurate according to the information provided by the participants.

---

Diahana L. Southard  
Bioanalyst

---

Lars Mouritsen  
Laboratory Manager